

# FUTURE PROOF HEALTHCARE

A sustainable healthcare for a new generation

## Company presentation

Life Science Investor Conference – 2023/04/19

Jonas Jarvius, CEO & President  
Anders Lundin CFO, IR



Q-LINEA 

# Disclaimer

THIS PRESENTATION AND ITS CONTENTS ARE CONFIDENTIAL AND ARE NOT FOR RELEASE, PUBLICATION OR DISTRIBUTION, IN WHOLE OR IN PART, DIRECTLY OR INDIRECTLY, IN OR INTO OR FROM THE UNITED STATES OF AMERICA, CANADA, AUSTRALIA, JAPAN OR ANY OTHER JURISDICTION WHERE SUCH DISTRIBUTION IS UNLAWFUL.

This presentation has been prepared and issued by and is the sole responsibility of Q-linea AB (the "Company") and is being furnished to each recipient solely for its own information and in connection with the preliminary discussions in relation to the Company. For the purposes of this disclaimer, "presentation" means these slides, their contents or any part of them, any oral presentation, any question or answer session and any written or oral materials discussed or distributed during the presentation meeting.

This presentation may not be copied, passed on, reproduced or redistributed, directly or indirectly, in whole or in part, or disclosed by any recipient, to any other person (whether within or outside such person's organisation or firm), and it may not be published anywhere, in whole or in part, for any purpose or under any circumstances. It is expressly forbidden to disclose the information in this presentation to any other person.

This presentation reflects the situation/information as of the date hereof and has not been independently verified and no representation or warranty, express or implied, is given by or on behalf of the Company, Carnegie Investment Bank AB (publ) (the "Manager"), any of their respective affiliates or any of such persons' respective directors, officers, employees, agents, affiliates or advisers as to, and no reliance should be placed on, the fairness, accuracy, completeness or correctness of the information or opinions contained in this presentation and no responsibility or liability is assumed by any such persons for such information or opinions or for any errors, omissions or misstatements contained herein.

This presentation contains summary information only and does not purport to be comprehensive and is not intended to be (and should not be used as) the sole basis of any analysis or other evaluation. The information set out in this presentation may be subject to updates, revisions, verifications and amendments without notice and the information may thus change materially. None of the Company, the Manager, any of their respective affiliates or any of such persons' respective directors, officers, employees, agents, affiliates or advisers is under an obligation to update or keep current the information contained in this presentation or to provide the recipient with access to any additional information that may arise in connection with it, and any opinions expressed in this presentation are subject to change without notice and none of them will have any liability whatsoever (in negligence or otherwise) for any loss whatsoever arising from any use of this presentation or otherwise arising in connection with this presentation.

This presentation does not constitute or form part of, and should not be construed as, any offer, invitation, solicitation or recommendation to purchase, sell or subscribe for any securities in any jurisdiction and neither the issue of the information nor anything contained herein shall form the basis of or be relied upon in connection with, or act as an inducement to enter into, any investment activity. This presentation does not purport to contain all of the information that may be required to evaluate any investment in the Company or any of its securities and should not be relied upon to form the basis of, or be relied on in connection with, any contract or commitment or investment decision whatsoever.

This presentation is intended to present background information on the Company, its business and the industry in which it operates and is not intended to provide complete disclosure upon which an investment decision could be made. The merit and suitability of an investment in the Company should be independently evaluated and any person considering such an investment in the Company is advised to obtain independent advice as to the legal, tax, intellectual property, accounting, financial, credit and other related advice prior to making an investment. The Company has not decided whether to proceed with any transaction.

To the extent available and unless otherwise explicitly stated, the industry and market data contained in this presentation has come from official or third-party sources. Third party industry publications, studies and surveys generally state that the data contained therein has been obtained from sources believed to be reliable, but that there is no guarantee of the accuracy or completeness of such data. While the Company believes that each of these publications, studies and surveys has been prepared by a reputable source, the Company has not independently verified the data contained therein. In addition, certain of the industry and market data contained in this presentation originates from the Company's own internal research and estimates based on the knowledge and experience of the Company's management in the market in which the Company operates. While the Company believes that such research and estimates are reasonable and reliable, they, and their underlying methodology and assumptions, have not been verified by any independent source for accuracy or completeness and are subject to change without notice. Accordingly, undue reliance should not be placed on any of the industry or market data contained in this presentation.

This presentation is only addressed to and directed at persons in member states of the European Economic Area ("EEA") who are qualified investors within the meaning of Article 2(1)(e) of the Prospectus Directive (Directive 2003/71/EC), as amended ("Qualified Investors"). In addition, in the UK, this presentation is addressed to and directed only at Qualified Investors who are persons who have professional experience in matters relating to investments falling within Article 19(5) of the Financial Services and Markets Act 2000 (Financial Promotion) Order 2005, as amended (the "Order"), are persons who are high net worth entities falling within Article 49(2)(a) to (d) of the Order or are persons to whom it may otherwise lawfully be communicated (all such persons being referred to as "relevant persons").

This presentation must not be acted on or relied on in the UK by persons who are not relevant persons and in any member state of the EEA other than the UK by persons who are not Qualified Investors. Any investment or investment activity to which this presentation relates is available only to relevant persons in the UK and Qualified Investors in any member state of the EEA other than the UK and will be engaged in only with such persons.

This presentation and the information contained herein are not an offer of securities for sale and are not for publication or distribution in the US or to persons in the US (within the meaning of Regulation S under the US Securities Act of 1933, as amended (the "Securities Act")), or any other jurisdiction where such distribution or offer is unlawful, except to qualified institutional buyers ("QIBs") as defined in Rule 144A under the Securities Act ("Rule 144A"). The Company does not intend to conduct a public offering of any securities in the US and the securities of the Company have not been and will not be registered under the Securities Act and may not be offered or sold in the US without registration except to QIBs in reliance on Rule 144A or another exemption from, or in transactions not subject to, the registration requirements of the Securities Act. Subject to certain limited exceptions, neither this presentation nor any copy of it may be taken, transmitted or distributed, directly or indirectly, into the US, its territories or possessions. Any failure to comply with the foregoing restrictions may constitute a violation of US securities laws.

Certain statements in this presentation may constitute forward-looking statements, beliefs or opinions, including statements with respect to the Company's business, financial condition and results of operations. These statements reflect the Company's beliefs and current expectations and involve risk and uncertainty because they relate to events and depend on circumstances that will occur or may change in the future are based on numerous assumptions regarding the Company's present and future business strategies and the environment the Company will operate in and are subject to risks and uncertainties that may cause actual results to differ materially. Forward-looking statements involve inherent known and unknown risks, uncertainties and contingencies because they relate to events and depend on circumstances that may or may not occur in the future and may cause the actual results, performance or achievements of the Company to be materially different from those expressed or implied by such forward looking statements. Many of these risks and uncertainties relate to factors that are beyond the Company's ability to control or estimate precisely, such as future market conditions, currency fluctuations, the behaviour of other market participants, the actions of regulators and other factors such as the Company's ability to continue to obtain financing to meet its liquidity needs, changes in the political, social and regulatory framework in which the Company operates or in economic or technological trends or conditions. As a result, you are cautioned not to place undue reliance on such forward-looking statements. Past performance should not be taken as an indication or guarantee of future results, and no representation or warranty, express or implied, is made regarding future performance. Some of the information is still in draft form and will only be finalised, if legally verifiable, at a later date. Forward-looking statements speak only as of their date and the Company, the Manager, their respective affiliates and any of such persons' respective directors, officers, employees, agents, affiliates or advisers expressly disclaim any obligation or undertaking to supplement, amend, update or revise any of the forward-looking statements made herein, except where it would be required to do so under applicable law.

The Manager is authorised by the Swedish Financial Supervisory Authority (Sw. Finansinspektionen) and is acting exclusively for the Company and no one else in connection with this presentation or any future transaction in connection with it. The Manager will not regard any other person (whether or not a recipient of this presentation) as a client and will not be responsible to anyone other than the Company for providing the protections afforded to their respective clients nor for the giving of advice in relation to any transaction, matter or arrangement referred to in this presentation.

THIS PRESENTATION IS BEING DELIVERED IN CONNECTION WITH A PROPOSED MEETING WITH THE COMPANY AND NO COPY OF THE PRESENTATION WILL BE LEFT BEHIND AFTER THE MEETING. BY ATTENDING THE MEETING WHERE THIS PRESENTATION IS MADE, YOU AGREE TO BE BOUND BY THE FOREGOING LIMITATIONS AND TO MAINTAIN ABSOLUTE CONFIDENTIALITY REGARDING THE INFORMATION DISCLOSED IN THIS PRESENTATION.

Headquarters, Marketing and demo lab, Consumable production in Uppsala

## Q-linea highlights



**Q-linea is developing disruptive solutions for faster infectious disease diagnostics, first product targeting sepsis**

**Planning & implementation of new commercialisation strategy**

Signed distribution agreements for the UK & Polish market

Building commercial organisation in the USA and Italy

Actively participating in several customer evaluations

**Progress toward US market**

Additional testing ongoing for the 510(k) application

Goal is to submit data in June

**Q-linea participates in several customer driven evaluation ASTar in Europe**

**Lead product ASTar®**



CE IVD

USD FDA  
Breakthrough device  
510k submitted in June



**EU-IVDR**

Q-LINEA 

# Q-linea facilities & staff

Headquarter, management, finance, HR & R&D



Commercial, training & demo



Consumable production and Instrument release





# Unique technology enables disruptive expansion pipeline & commercial opportunities

## Blood culturing

TRADITIONAL TECHNOLOGY



### Podler®



**Portable blood culturing and readout.** Equally fast as current state-of-the art stationary cabinets\*. But use transportation time for fastest TTR. **Next big leap in blood culturing...**

Q-LINEA TECHNOLOGY

## Identification

### Mass spec



### Molecular



### ASTrID®



**Highly multiplexed molecular ID analysis followed by AST**

Proof-of-principle: **>25 plex** pathogen analysis **direct** from venous blood. Patient study.

## Susceptibility testing



### ASTar®



CE-IVD, BC G-



### ASTrea™



POC

Proof-of-principle 45 min AST for urine analysis

Q-linea technology is covered by 24 patent families

## Urgent need for improved infectious disease diagnostics

### **Sepsis is the most common cause of death in our hospitals**

More common than lung + prostate + breast-cancer **combined**

Accounts for approximate 30% of all deaths in the hospital

Most expensive condition to treat in the US. >27B USD<sup>1)</sup>

### **Time to correct treatment is critical!**

7.6% decrease of survival rate for every hour of delay of effective therapy<sup>2)</sup>

Improved diagnostics needed today and for future generations

**Antimicrobial resistance is dramatically increasing**

Today treatment of infections is difficult due to bacterial resistance

**Treatment is based on assessments (empiric) not on diagnostics**

**Many treatments are ineffectual or unnecessary**

Has been presented as

**“Greatest threat to mankind”**

# ASTar – designed to save lifetimes

Developed together with our future customers

## Easy to use

- Fully automated
- ~2 min hands-on time
- Load-and go workflow

## Fast

- Results in ~6 hours
- High throughput
- 12 samples in parallel



## Comprehensive

- Large antibiotic panel
- Long concentration ranges
- Fastidious and non-fastidious bacteria
- Support additional samples (*e.g.* urine)

## Accurate

- True MIC results
- High reproducibility

**ASTar classified as a breakthrough device by the FDA**



# Large addressable market for rapid AST diagnostics instruments

ASTar has several potential target markets



## Sepsis

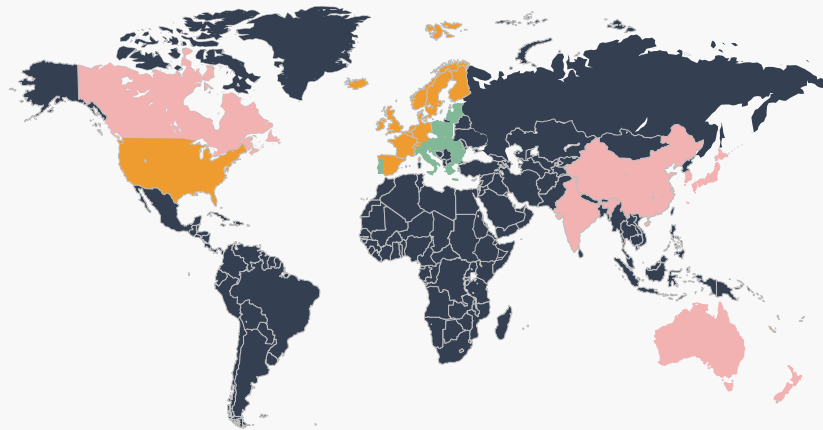

Key: ■ Primary markets ■ Other interesting markets ■ Markets recognizing CE/IVD marking

## Number of Antimicrobial Susceptibility Tests for *in vitro* diagnostics

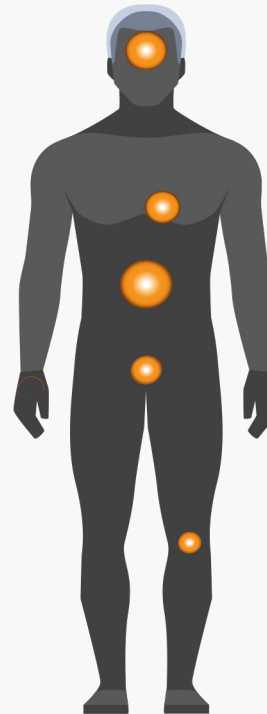

## LRTI

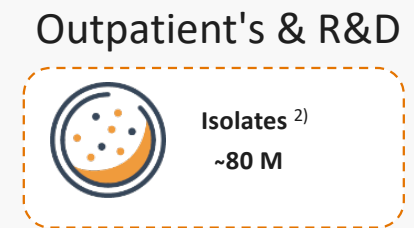
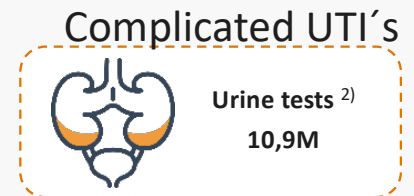

1) Blood from positive blood culture. Source: Management account on estimated annual addressable market volume, US + CE + APAC,

2) Management account on estimated annual addressable market volume, US + CE

# Up to 48 hours faster actionable results

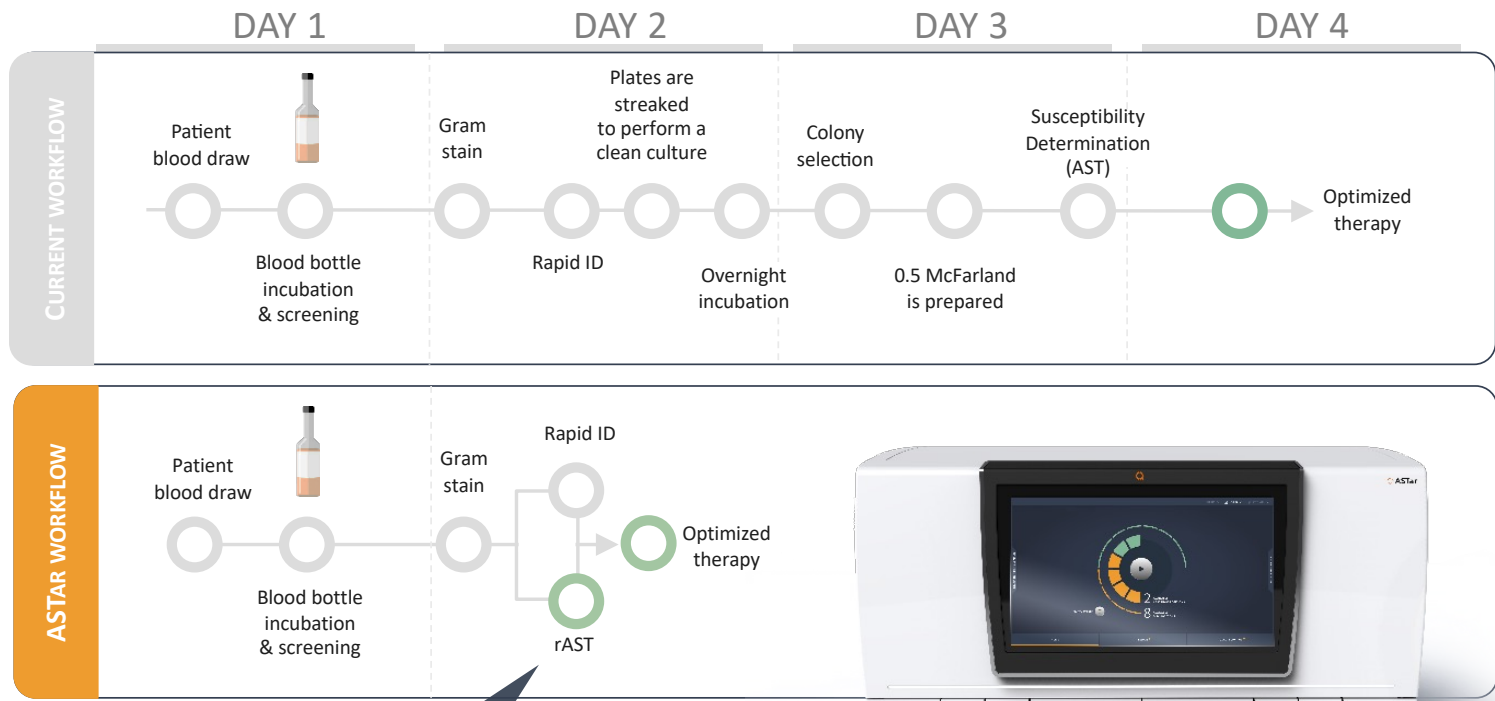

Time to Actionable results is what matters for septic patients

A broad panel, >25 antibiotics  
Enable start of AST AND ID at the same time



# ASTar makes a difference in patient outcome

Patient-case from first commercial evaluation in Sweden

## Patient

- Man, 64, surgery department
- Empiric treatment  
Piperacillin/tazobactam

## ASTar results

- ASTar results **at least 18 h earlier** than Std-AST.
- MIC results from **13 additional antibiotics**
- Resistant against initial treatment (pip/tazo)

## Timeline

Day 1

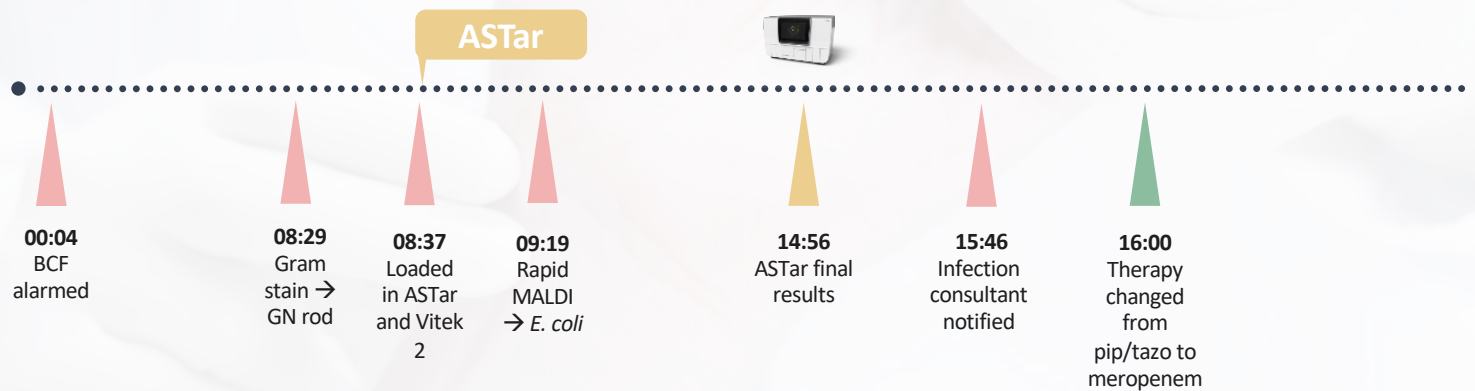

# Health economic benefits of faster **24 hours** faster diagnostics

## Lower mortality

Up to 40%  
lower mortality rates<sup>1)</sup>

## Less pressure for resistance and superinfections

Up to 25%  
reduction of *C. difficile*  
infections<sup>2)</sup>

## Cost savings

~\$2,500 – \$20,000  
cost savings per patient<sup>3)</sup>



ASTar can provide **up to 48 hours** faster diagnostics

Source: 1) Patel et al, *J Clin Microbiol.* 2017 Jan; 55(1): 60–67., ECCMID 2017, poster OS1033, Andreassen et al. Cost-effectiveness of MALDI-TOF and rapid antimicrobial susceptibility testing for high-risk patients, Huang et al. *Clin Infect Dis.* 2013 Nov; 57(9): 1237-45. 2) Fridkin et al, *MMWR*, 2014;63(9), 194-200. 3) Perez et al, *Arch Pathol Lab Med* 137:1247-1254, 2013, Perez et al *J Infect.* 2014 Sep;69(3):216-25, 2014, Bauer et al *Clin Infect Dis* 51:1074-1080, 2010. ) Patel et al, *J Clin Microbiol.* 2017 Jan; 55(1): 60–67.

## ASTar performance is strong and it is easy to use

*Evaluation of commercial systems for rapid antimicrobial susceptibility testing (rAST) of positive blood cultures: Comparison of susceptibility results*

View Sheffield Hospital's scientific poster presentation from ECCMID 2022, featuring the ASTar System.

***ASTar's panel covered 95,4% of all organisms included in the study.***

**“ASTar fits right into our processes and systems”**

Robert Price, Senior Biomedical Scientist, Whiston Hospital, UK



*Large multicentre evaluation in Germany and UK.*

*Covered 500 ASTar determinations on routine clinical samples. Compared against both Sensititre™, Vitek® and multipoint.*

***ASTar's panel covered 98,7% of all organisms included in the study.***

***Essential agreement (EA) >96,6%.***



# ASTar enables anyone at the lab to load samples anytime

User friendly  
& 24/7 availability

Add sample

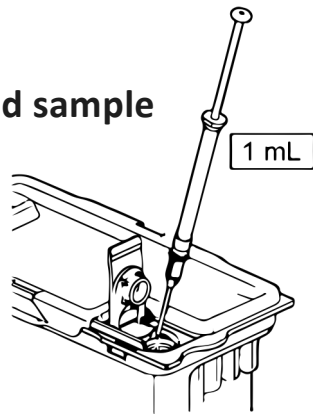

1 mL

Click "start"

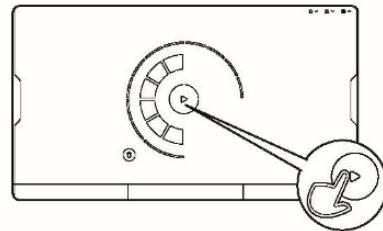

Scan barcode

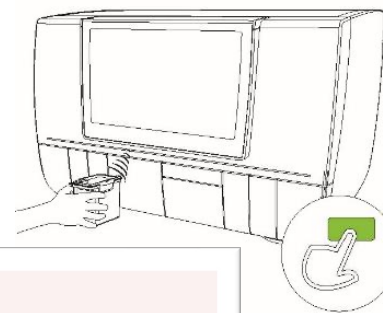

Load AST disc

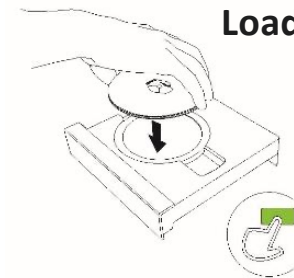

Add sample  
barcode

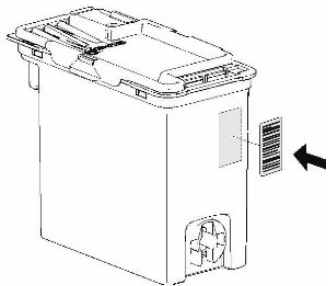

**”**  
**User testimonial;  
How ASTar has helped  
save time in the lab**  
Listen to Ehsan Ghaderi, Head of Dept,  
and Sofia Persson, Consultant  
Physician, Bacteriology, Uppsala  
University Hospital, Sweden

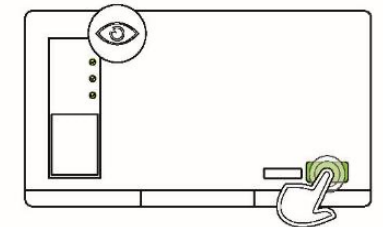

Click "Start run"

# High throughput and flexible solution

Our ambition was the most user friendly and capable system

High throughput & flexible



=

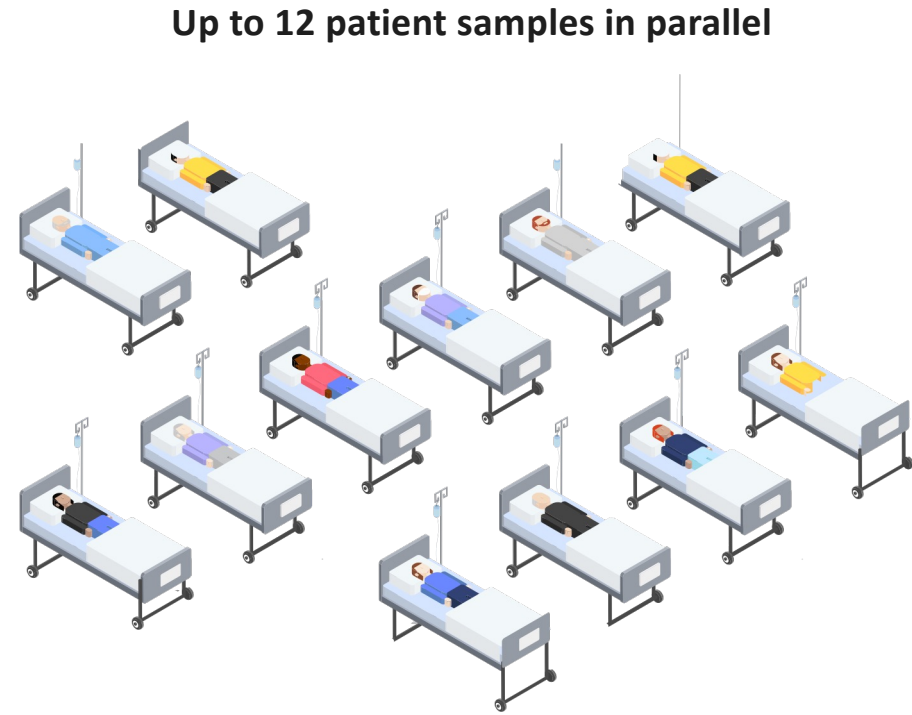

Fully automatic    Semi automatic





Consumables stored at room temp and a small insert at -20°C.

Compatible with small and large (e.g. urine) sample volumes, and to run isolates separately

# Excellent and accurate data from the CE-IVD clinical study

Broadest panel enabling actionable results

FDA and ISO requirements <sup>1,2)</sup>		
Essential agreement = Same MIC value as reference		
FDA	ISO	Q-LINEA 
89.9%	90%	<b>94.7%<sup>3</sup></b>
Categorical agreement = Correct treatment recommendation		
FDA	ISO	Q-LINEA 
89.9%	90%	<b>97.6%<sup>3</sup></b>
Reproducibility		
FDA	ISO	Q-LINEA 
95%	95%	<b>99.6%<sup>3</sup></b>

The ASTar<sup>®</sup> Instrument and ASTar<sup>®</sup> BC G- Kit offer the **broadest combination of antimicrobials and dilution ranges** in a single analysis for Gram-negative bacteria <sup>6</sup>. The analysis also **delivers true MIC results**.

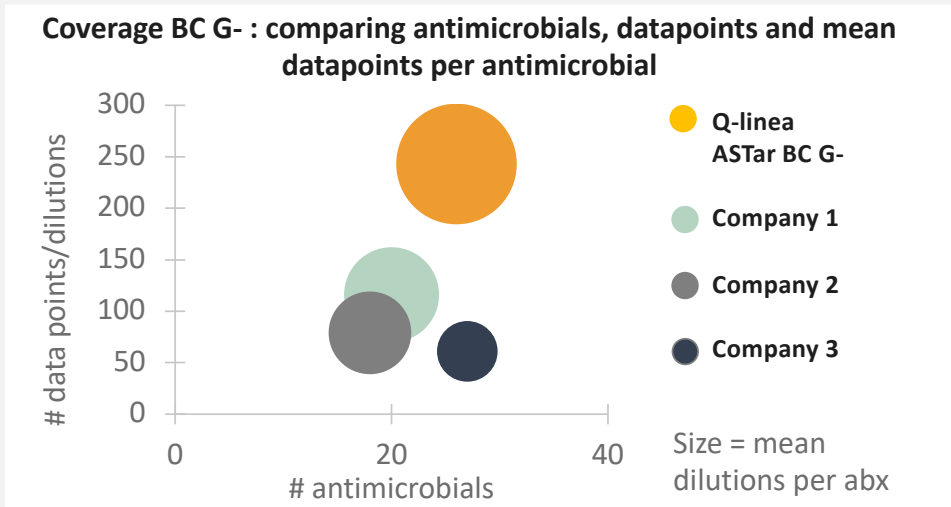

16 Source: 1) ISO 20776-2, Clinical laboratory testing and in vitro diagnostic test systems — Susceptibility testing of infectious agents and evaluation of performance of antimicrobial susceptibility test devices: - Part 2: Evaluation of performance of antimicrobial susceptibility test devices 2) Guidance for Industry and FDA Class II Special Controls Guidance Document: Antimicrobial Susceptibility Test (AST) Systems, August 28, 2009, FDA document number 631.3) Company results from CE-IVD clinical study for BC G-, Gram negative antibiotic panel 2020-05-04 6) Based on commercially available systems market overview May 2021



# Updated commercialisation strategy – first stage in 2023

Initially focus on key geographies in Europe and East coast in the USA & at the same time manage costs

**Goal is to demonstrate ASTar commercially & Enable a strong ramp-up in 2024**



## USA – Q-linea Inc.

**Most important market due to size and demonstrated to be more mature for rAST than Europe**

**Pre-FDA evaluations in discussions with two hospitals**

**Will be approached using internal sales force & regional office**

## UK

**Important market due to size and sepsis awareness**

**Will be approached using distributor**



## Italy – Q-linea S.r.l

**Important market due to size and demonstrated interest of ASTar**

**Base for first HEOR study**

**Will be approached using internal sales force & regional office**

**Benelux**  
**Important market due to market leading KOL's**

**PK/PD driven antibiotic treatment**

**Will be approached using internal sales force, but no regional office**

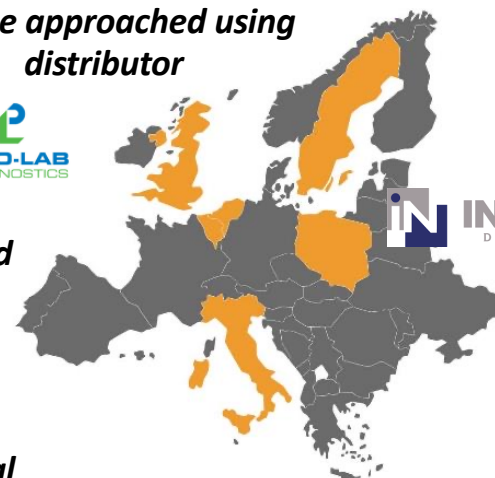

## Poland

**Large focus on sepsis in 2023**

**Will be approached using distributor**



Time to actionable result is what matters for  
septic patients

What if time  
wasted could be  
time used?

Equal and better  
care for everyone

We aim to transform infectious disease  
diagnostics

Q-LINE



# Up to 48 hours faster actionable results

Transportation of blood culture from patient to laboratory:  
1 – 24+ hours

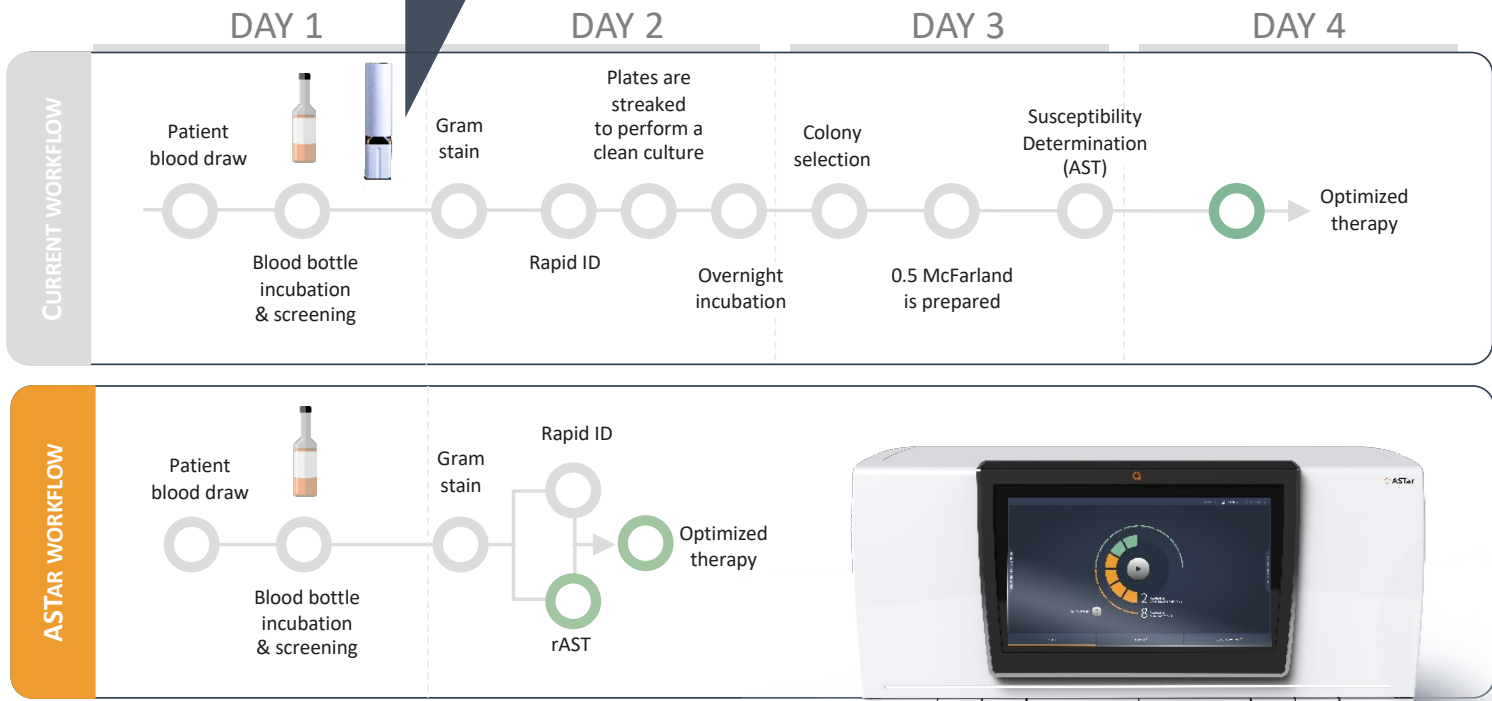

Time to Actionable results is what matters for septic patients



# Unique technology enables disruptive expansion pipeline & opportunities

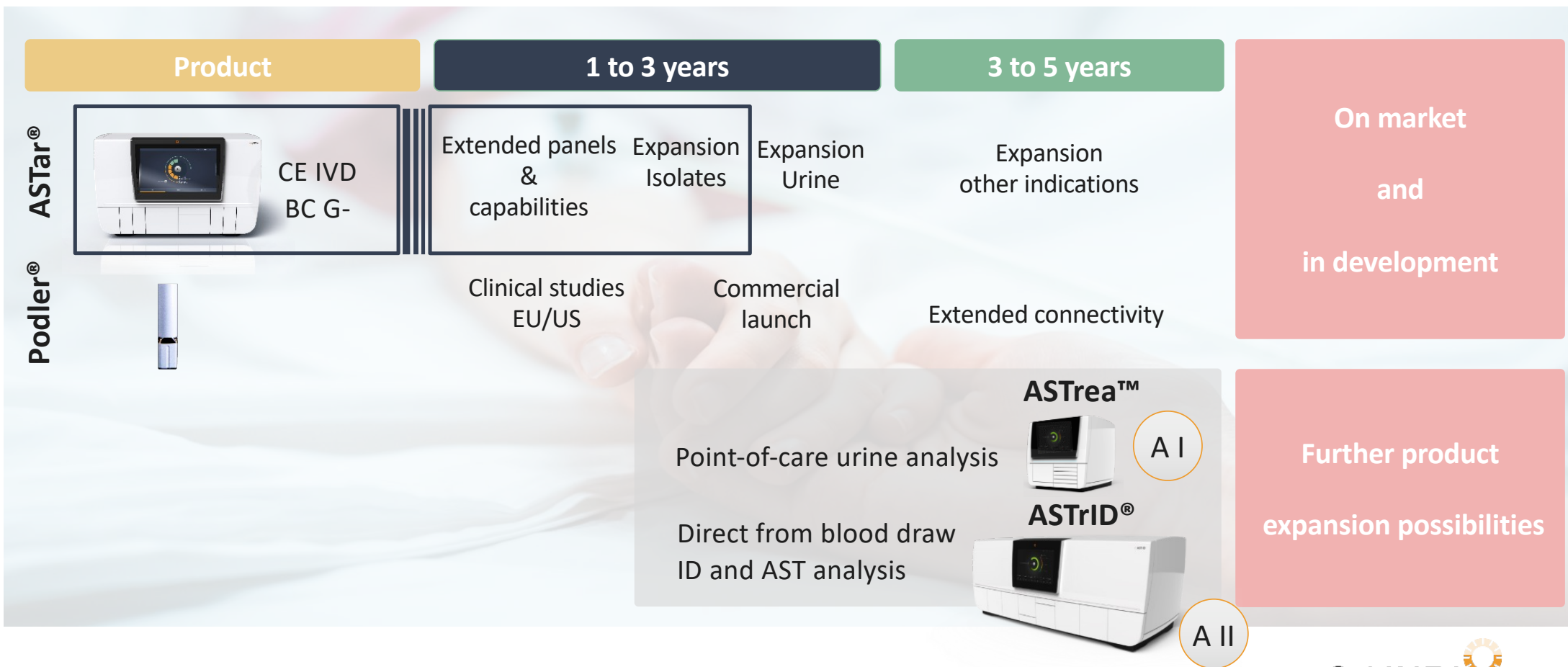

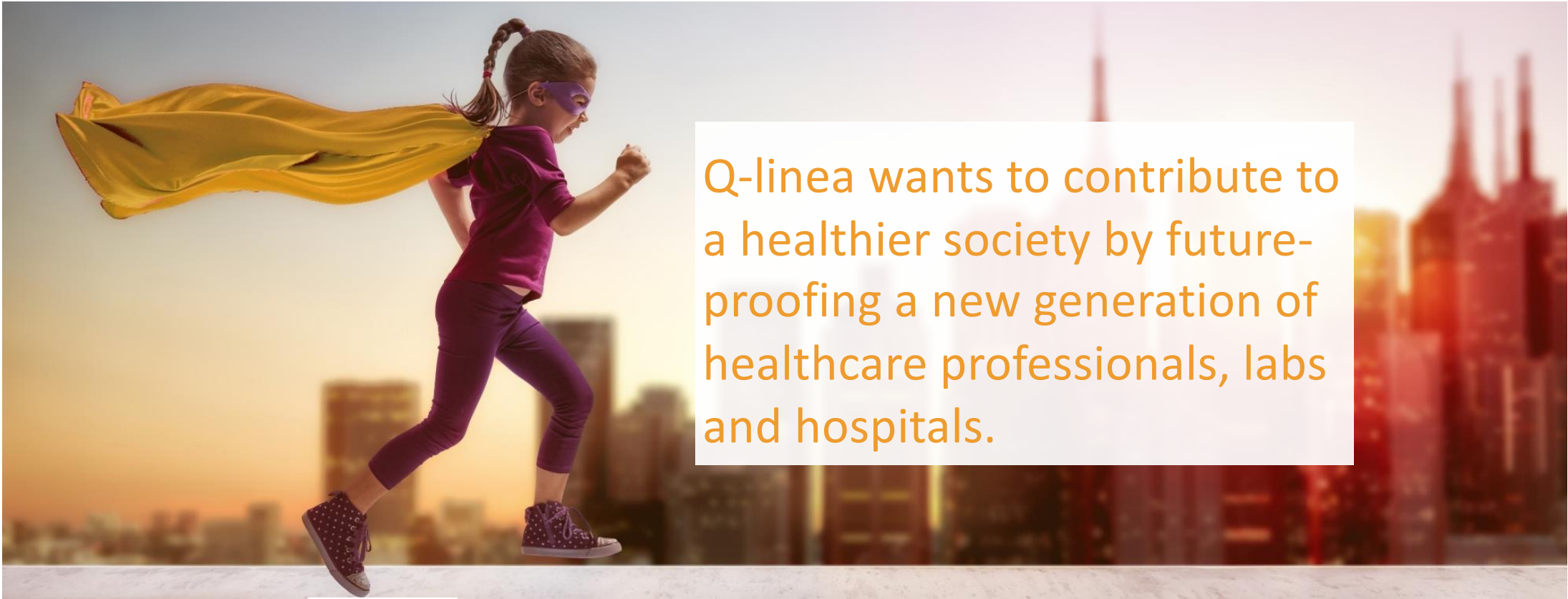

Q-linea wants to contribute to a healthier society by future-proofing a new generation of healthcare professionals, labs and hospitals.

**Thank you**